

8	7	6	5	4	3	2	1
MODEL DESIGNATION	DIMENSIONS TO OUTER FLANGE A x B x C (in inches)	PART NUMBER	CFM	EFF.	PRESSURE DROP (in. W.G.)		
FA1560-01-01	24 X 24 X 11-1/2	855010008	2400	99.99	1.0		

Note: Contact factory for sales drawings on other sizes

- MATERIAL NOTES:**
1. FILTER MEDIA: MICRO-GLASS FIBER / ACRYLIC RESIN BINDER
 2. FRAME MAT'L: 6063-T5 ANODIZED ALUMINUM (SHOWN)
 3. SEALANT MAT'L: FIRE RETARDANT/PHOSPHORUS FREE TWO PART POLYURETHANE
 4. GASKET MATERIAL: SEAMLESS FOAM GASKET, DOWNSTREAM

- TESTING NOTES:**
1. EACH FILTER SHALL BE TESTED FOR EFFICIENCY IN ACCORDANCE WITH IEST-RP-CC-007.

- FILTER SPECIFICATIONS:**
- PLEAT DEPTH: 27.5mm
 - EFFICIENCY: SEE TABULATION
 - MAX. OPERATING TEMP: 175° F
 - MAX. REL. HUMIDITY: 99%

- UL RATINGS:**
1. FILTERS MEET UL-586 AND UL-900.

- FRAME TOLERANCES:**
- LENGTHS: +0, -1/16"
 - DIAGONALS: WITHIN 1/8" TOTAL ALLOWANCE FOR DIAGONALS < 30 in.
WITHIN 1/4" TOTAL ALLOWANCE FOR DIAGONALS ≥ 30 in.

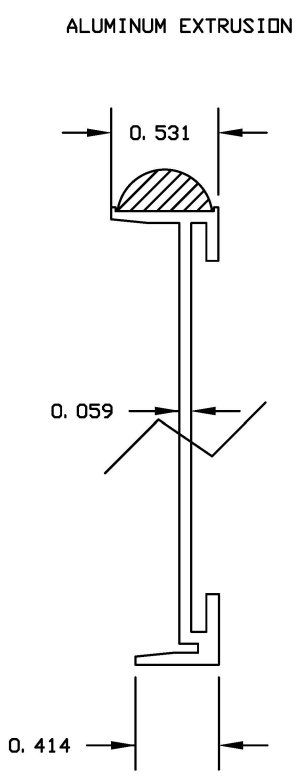
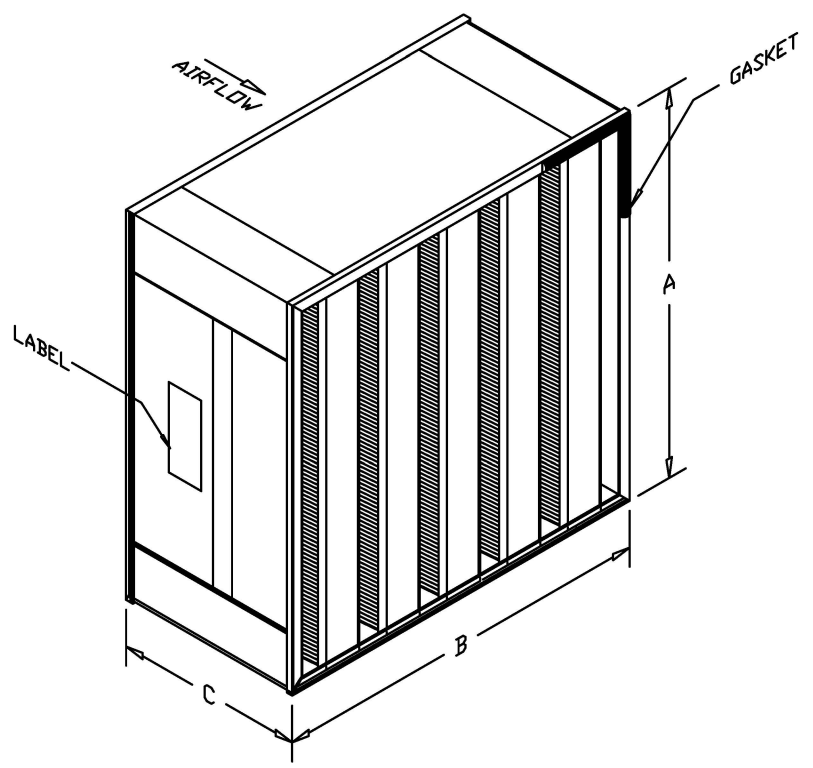

CUSTOMER APPROVAL BLOCK

YOUR APPROVAL OF THIS PRINT AUTHORIZES CAMFIL USA INC. TO PROCEED WITH MATERIAL PROCUREMENT, TOOLING AND PRODUCT FABRICATION. ANY CHANGES MADE AFTER APPROVAL MAY INCUR FURTHER EXPENSES TO THE CUSTOMER.

OK AS IS SEND REVISED DWG.

SIGNATURE/DATE _____

COMPANY NAME _____

APPROVED BY:	DATE:	DRAWN BY:	DATE:
SM	6/1/2023	JJG	10/5/06



©Camfil USA Inc. <http://www.camfil.com>

DESCRIPTION
FA1560-01-01
CUSTOM FILTRA 2000

SHEET	DRAWING NUMBER	REV.
1 of 1	501065	A